

ATLAS

Material Handler 180MH / 200MH

FAST. RELIABLE. VERSATILE.

180MH / 200MH



18,8 - 19,2 t / 19,6 - 20 t



95 kW (130 PS) / 105 kW (143 hp)



10,1 m



Technical specifications

ENGINE

Power according to ISO 9249...95 kW (130 hp) / 105 kW (143 hp)	Number of cylinders4 / 6	Alternator..... 24 V / 55 Ah
RPM1800/min	Borehole/lift101 / 126	Starter24 V / 4 kW / 24 V / 4,8 kW
Make..Deutz TCD 4.1 / Deutz TCD 6.1 (Stage 3B)	Cooling system water-cooled	
Design..... Turbocharger / intercooler	Air filterDry air filter	
Cylinder capacity4038 / 6057 cm ³	Battery 2 x 12 V / 100 Ah	

HYDRAULIC SYSTEM

<ul style="list-style-type: none"> • AWE 5 system (load sensing) • Load limit controlled high-performance pump 	<ul style="list-style-type: none"> • Suction valves for all work functions • Load-retaining and fine-lowering valve in lifting circuit • Pipe-break protection valves for lifting cylinders • Grab and grab-rotating function • 2 additional circuits for additional consumer loads possible 	<ul style="list-style-type: none"> • Cylinder end-position damping • Temperature-controlled fan for cooler • Max. discharge flow260 l/min • Max. operating pressure.360 bar • Operating modes: 3 pre-programmed modes (Fine, Eco, Power)
<ul style="list-style-type: none"> • Fuel-efficient flow-on-demand control • Sensitive, proportional, independent steering • Primary and secondary protection against overload 		

SWING ASSEMBLY

<ul style="list-style-type: none"> • Swing motor: • Swing gear: • Swing brake: 	<ul style="list-style-type: none"> • Axial piston motor with priority valve • Planetary transmission • Automatic multidisc brake 	<ul style="list-style-type: none"> • Max. swing speed.9/min • Swing torque39,8 / 41 kNm
---	---	--

TRACTION DRIVE AND BRAKES

<ul style="list-style-type: none"> • Variable displacement motor • Power-shift transmission • Double-acting brake valve • Driving direction pre-selection via switch in joystick 	<ul style="list-style-type: none"> • Automotive drive and cruise control: • Maximum speed20 km/h • Terrain speed5 km/h • Crawling speed.....1 km/h 	<ul style="list-style-type: none"> • Dual circuit brake system Multi-disc • Parking brake Multi-disc
--	--	--

UNDERCARRIAGE

<ul style="list-style-type: none"> • 28 t special excavator axles: 	<ul style="list-style-type: none"> • Steering axle with automatic oscillating axle blocking 	<ul style="list-style-type: none"> • 8 tyres. 10.00 - 20
---	--	--

FILL CAPACITIES

<ul style="list-style-type: none"> • Fuel tank264 liter • Cooling system38 liter 	<ul style="list-style-type: none"> • Engine oil.....10 liter • Hydraulic tank180 liter 	<ul style="list-style-type: none"> • Hydraulics system350 liter
--	--	--

DRIVER'S CAB

<ul style="list-style-type: none"> • Meets latest safety standards • Extra large entry zone • Spacious leg room • Excellent circumferential visibility • Preparation for radio installation with mute function 	<p>CONTROL:</p> <ul style="list-style-type: none"> • Ergonomic joysticks • Slim steering column, height and tilt adjustable • Indicators, controls and operating switches are clearly arranged 	<p>CLIMATE CONTROL:</p> <ul style="list-style-type: none"> • Air conditioning equipped as standard • Very good air distribution through optimally arranged nozzles
<p>DRIVER'S SEAT:</p> <ul style="list-style-type: none"> • Air-cushioned comfort seat (optional seat heating) • Arm rests and lumbar support • Seat adjustable separately from console 	<p>MONITORING:</p> <ul style="list-style-type: none"> • Operating data display screen • Automatic system for monitoring, warning and storage of data 	<p>SOUND LEVELS:</p> <ul style="list-style-type: none"> • ISO 6396 (LpA) in driver's cab..... 70 dB(A) • 2000/14EG (LwA) ambience level.....97 dB(A)

180MH/200MH

Working equipment

OPERATING WEIGHTS

	LOADING BOOM 6,00 m (C6.6i)		ADJUSTABLE BOOM Main arm 1,87 m (C6.41) Boom 3,10 m (C6.46)
	Stick 4,00 m (D6.14i)	Stick 4,00 m (D6.14ig)	Stick 2,65 m (D6.3)
DB / outriggers	18,8 t / 19,6 t	19 t / 19,8 t	19 t / 19,8 t
4 outriggers	19 t / 19,8 t	19,2 t / 20 t	19,2 t / 20 t

Operating weight with driver, solid rubber tyres, completely filled implement and 1.3 tons for attachments

EQUIPMENT

BASIC DEVICE ATLAS 180MH / 200MH

- 180MH / 200MH material handler with quadruple outrigger support and 2 lifting cylinders (A 5.32i / A 7.32i)
- 180MH / 200MH material handler with DB* on rigid axle, double outrigger support on steering axle and 2 lifting cylinders (A5.33i / A7.33i)
- 180MH/200 MH with DB on steering axle, double outrigger support on rigid axle and 2 lifting cylinders (A5.3i / A7.35i)

* DB - Dozer blade

STANDARD EQUIPMENT:

Engine:

- Automatic idle
- Diesel pre-filter
- Engine monitoring

- Radio preparation with mute function

- Ready for electric cooling box

- Different options for storage, compartment for documents

- Seat adjustable separately from console

- Rear view security camera with 5" LCD-colour monitor

- Heat-absorbing glass, tinted windows

- Automotive drive and cruise control

BOOMS:

- Loading boom with bending cylinder 6,0 m (C 6.6i)
- Adjustable boom consisting of the main arm 1,87 m (C 6.41) with adjustable cylinder and boom 3,1 m (C 6.46) with stick cylinder

Hydraulics

- Grab and grab-rotating function
- Accumulator for emergency lowering of the arm system
- Pipe break protection valves for lifting cylinders

- Operating data display screen

- Bottle holder

STICKS:

- Stick 2,65 m (D6.3)
- Stick 4,00 m (D6.14)
- Stick for sorting grapple 4,00 m (D6.14ig)

- Max. load-limit control

- Cylinder end-position damping

EQUIPMENT:

- Joint bearings in stick and bucket cylinders
- Combined lubricating points for swing bearing and arm equipment

BUCKET TIPPING CYLINDER:

- Bucket tipping cylinder with bucket linkage (F6.1)

Cab:

- Air-conditioning
- Slim steering column, height and tilt adjustable

UNDERCARRIAGE:

- Power-shift transmission
- Wet disc brakes
- Tool box in the undercarriage

ADDITIONAL EQUIPMENT

Engine:

- Refueling pump
- Engine speed adjustment via potentiometer
- Auxiliary heating
- Cold start assistance

Cab:

- Cab protection guard
- Beacon light
- Heated driver's seat
- GPS/GSM telemetric system for monitoring of operating data, consumption, position
- Radio/CD/MP3, front AUX in, USB
- Xenon working lights

Undercarriage:

- Wide axles (overall width 2750 mm)
- Wide dozer blade (overall width 2750 mm)
- Solid rubber tyres

Hydraulics:

- Hydr. adaptor kit, switch supports pairwise in front and back
- Hydr. adaptor kit, switch supports individually
- Biodegradable oil

- Lift-cabin - 2m elevation

- Cab elevation 1.20 m

- Pressurized cabine

- Electric cooling box

Other special equipment: See price list

Equipment:

- Central lubrication system

ATTACHMENTS

- Clamshell grab
- Orange peel grab
- Load hook
- Load lifting magnet
- Log grab
- Sorting grapple

Working ranges Loading boom 6,0 m (C6.6i) + Stick 4,0 m (D6.14i)

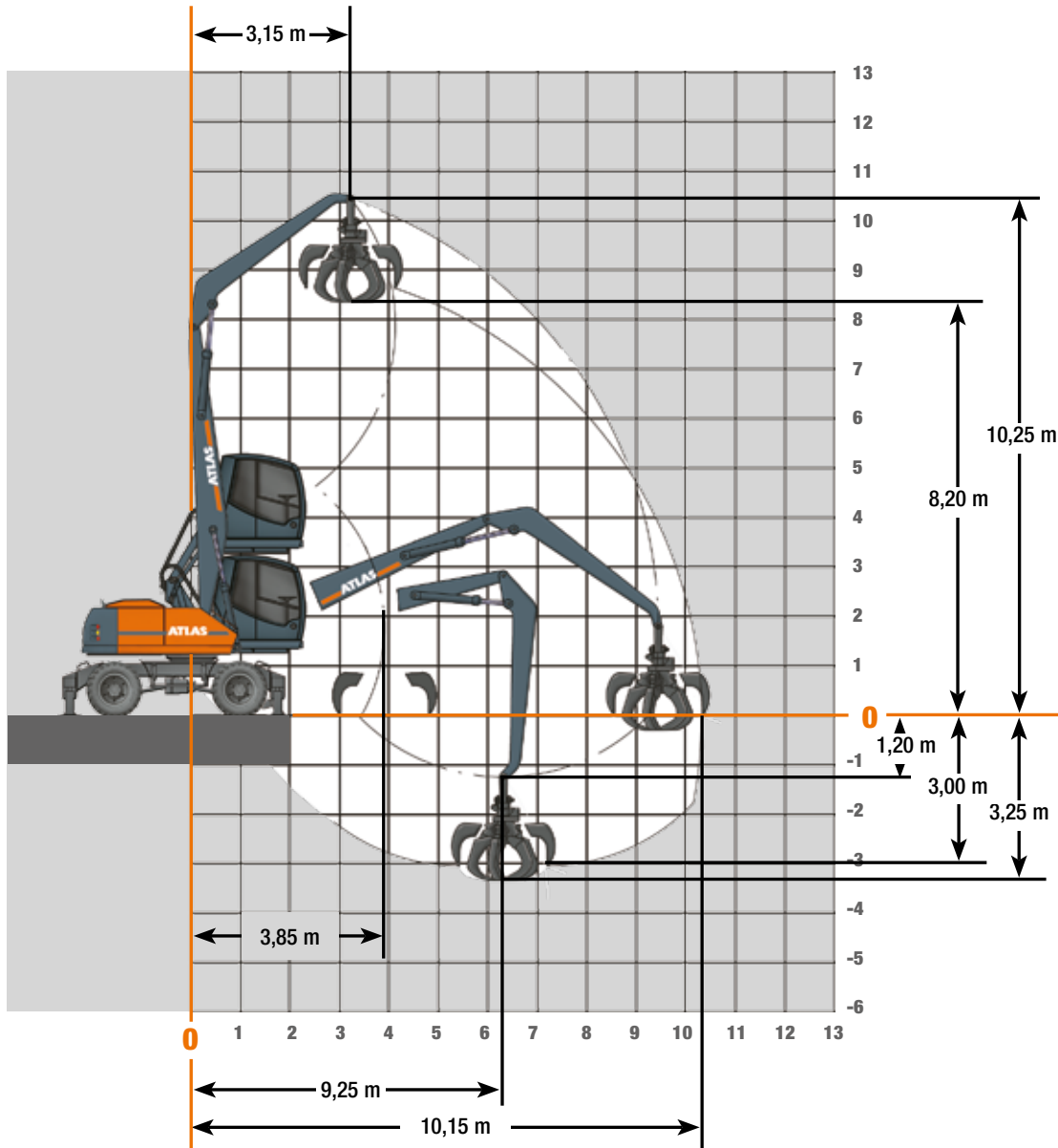

Attachments

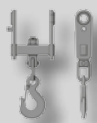

Load hook

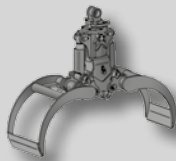

Log grab

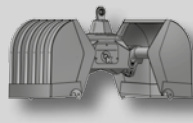

Clamshell grab

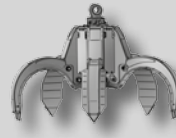

Orange peel grab

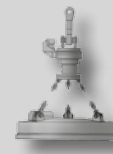

Load lifting magnet

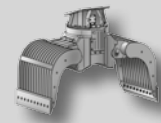

Sorting grapple

180MH/200MH

Lifting capacities Loading boom 6,0 m (C6.6i) + Stick 4,0 m (6.14i)

Lifting capacities 180MH: Loading boom 6,0 m (C6.6i) with Stick 4,0 m (D6.14i). Max. reach 10,15 m

HEIGHT		2,5 m		4,0 m		5,5 m		7,0 m		8,5 m	
		FRONT	LATERAL	FRONT	LATERAL	FRONT	LATERAL	FRONT	LATERAL	FRONT	LATERAL
+ 9,0 m	outriggers down			7,8*	7,8	6*	5,2				
	outriggers up			7,8*	5	5,3	3,1				
+ 7,5 m	outriggers down			8*	8*	5,9*	5,2	4,2	3,5		
	outriggers up			8*	5	5,4	3,1	3,6	2,1		
+ 6,0 m	outriggers down			7,8*	7,8*	6*	5,2	4,2	3,5		
	outriggers up			7,8*	5	5,3	3,1	3,6	2,1		
+ 4,5 m	outriggers down	6,7*	6,7*	8,4*	8,4*	6	5	4,1	3,4	3	2,5
	outriggers up	6,7*	6,7*	8,4*	4,8	5,1	2,9	3,5	2	2,6	1,4
+ 3,0 m	outriggers down			9,1*	7,9	5,8	4,8	4	3,3	3	2,5
	outriggers up			8,2	4,3	4,9	2,7	3,4	1,9	2,5	1,4
+ 1,5 m	outriggers down			9*	7,3	5,5	4,5	3,8	3,2	2,9	2,4
	outriggers up			7,6	3,8	4,7	2,5	3,3	1,8	2,5	1,4
0 m	outriggers down			5,6*	5,6	5,3	4,4	3,7	3,1	2,9	2,4
	outriggers up			5,6*	3,6	4,5	2,4	3,2	1,7	2,4	1,3
- 1,0 m	outriggers down					4,7*	4,3	3,6*	3,1		
	outriggers up					4,4	2,3	3,2	1,7		

Lifting capacities 200MH: Loading boom 6,0 m (C6.6i) with Stick 4,0 m (D6.14i). Max. reach 10,15 m

HEIGHT		2,5 m		4,0 m		5,5 m		7,0 m		8,5 m	
		FRONT	LATERAL	FRONT	LATERAL	FRONT	LATERAL	FRONT	LATERAL	FRONT	LATERAL
+ 9,0 m	outriggers down			7,8*	7,8	6*	5,8				
	outriggers up			7,8*	5,7	5,9	3,5				
+ 7,5 m	outriggers down			8*	8*	5,9*	5,8	4,6	4		
	outriggers up			8*	5,7	5,9*	3,6	4	2,4		
+ 6,0 m	outriggers down			7,8*	7,8*	6*	5,8	4,6	3,9		
	outriggers up			7,8*	5,7	5,9	3,5	4	2,4		
+ 4,5 m	outriggers down	6,7*	6,7*	8,4*	8,4*	6,3	5,6	4,5	3,9	3,4	2,9
	outriggers up	6,7*	6,7*	8,4*	5,4	5,7	3,4	4	2,3	2,9	1,7
+ 3,0 m	outriggers down			9,1*	8,9	6,4	5,4	4,4	3,7	3,3	2,8
	outriggers up			9,1*	4,9	5,5	3,2	3,8	2,2	2,9	1,7
+ 1,5 m	outriggers down			9*	8,3	6,1	5,1	4,3	3,6	3,3	2,8
	outriggers up			8,5	4,5	5,3	2,9	3,7	2,1	2,8	1,6
0 m	outriggers down			5,6*	5,6*	5,6*	5	4,2	3,5	3,1*	2,7
	outriggers up			5,6*	4,2	5,1	2,8	3,6	2,1	2,8	1,6
- 1,0 m	outriggers down					4,7*	4,7*	3,6*	3,5		
	outriggers up					4,7*	2,8	3,6*	2		

The specified max. loading capacities in tonnes include a stability of 33% or are calculated at 87% of the hydraulic lifting power, as per ISO10567. These values are applicable at the tip of the arm with optimum positioning of the corresponding arm system. * Value limited due to hydraulics. Weights of attached load carrying accessories (grab, magnet, load hook, etc.) are not included with the load carrying values.

Working ranges Loading boom 6,0 m (C6.6i) + Stick 4,0 m (D6.14ig)

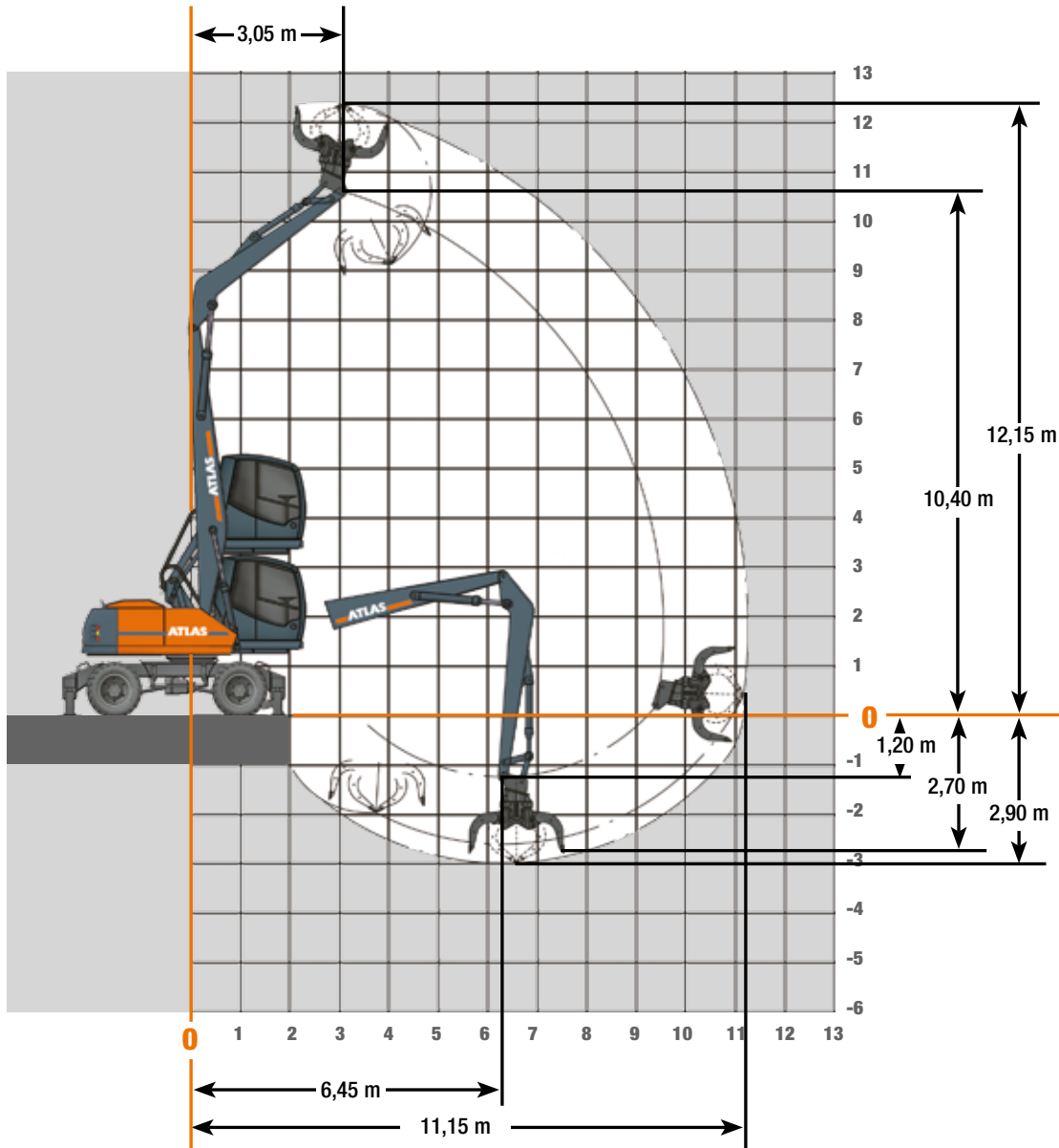

Attachments

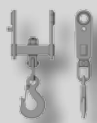

Load hook

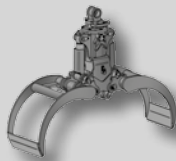

Log grab

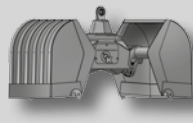

Clamshell grab

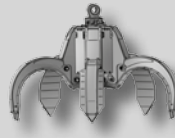

Orange peel grab



Load lifting magnet

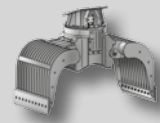

Sorting grapple

180MH/200MH

Lifting capacities Loading boom 6,0 m (C6.6i) + Stick 4,0 m (D6.14ig)

Lifting capacities 180MH: Loading boom 6,0 m (C6.6i) with Stick 4,0 m (D6.14ig) Max. reach 11,05 m

HEIGHT		2,5 m		4,0 m		5,5 m		7,0 m		8,5 m	
		FRONT	LATERAL	FRONT	LATERAL	FRONT	LATERAL	FRONT	LATERAL	FRONT	LATERAL
+ 9,0 m	outriggers down			7,8*	7	6*	4,5				
	outriggers up			7,8*	4,9	5,3	3				
+ 7,5 m	outriggers down			8*	7	5,9*	4,5	4,3	3,1		
	outriggers up			7,9	4,9	5,1	3	3,4	2		
+ 6,0 m	outriggers down			7,8*	7*	6*	4,5	4,2	3		
	outriggers up			7,8*	4,9	5,1	3	3,4	2		
+ 4,5 m	outriggers down	7,7*	7,7*	8,4*	7,3	6,1	4,3	4,2	3	3,1	2,2
	outriggers up	7,7*	7,7*	8,3	4,7	4,9	2,8	3,4	1,9	2,5	1,4
+ 3,0 m	outriggers down			9,1*	6,7	5,9	4,1	4	2,9	3	2,1
	outriggers up			7,8	4,2	4,7	2,6	3,2	1,8	2,4	1,4
+ 1,5 m	outriggers down			9*	6,1	5,6	3,9	3,9	2,7	3	2,1
	outriggers up			7,2	3,7	4,4	2,4	3,1	1,7	2,4	1,3
0 m	outriggers down			6,1*	5,9	5,5	3,7	3,8	2,7	2,9	2
	outriggers up			6,1*	3,5	4,3	2,3	3	1,7	2,3	1,3
- 1,0 m	outriggers down					4,7*	3,7*	3,6*	2,6*		
	outriggers up					4,2*	2,2*	3	1,6*		

Lifting capacities 200MH: Loading boom 6,0 m (C6.6i) with Stick 4,0 m (D6.14ig) Max. reach 11,05 m

HEIGHT		2,5 m		4,0 m		5,5 m		7,0 m		8,5 m	
		FRONT	LATERAL	FRONT	LATERAL	FRONT	LATERAL	FRONT	LATERAL	FRONT	LATERAL
+ 9,0 m	outriggers down			7,8*	7,8*	6*	5				
	outriggers up			7,8*	5,6	5,7	3,5				
+ 7,5 m	outriggers down			8*	7,9	5,9*	5,1	4,7	3,5		
	outriggers up			8*	5,6	5,7	3,5	3,9	2,4		
+ 6,0 m	outriggers down			7,8*	7,8*	6*	5	4,7	3,4		
	outriggers up			7,8*	5,6	5,7	3,5	3,9	2,4		
+ 4,5 m	outriggers down	7,7*	7,7*	8,4*	8,1	6,3*	4,9	4,6	3,4	3,4	2,5
	outriggers up	7,7*	7,7*	8,4*	5,3	5,5	3,3	3,8	2,3	2,8	1,7
+ 3,0 m	outriggers down			9,1*	7,8	6,5*	4,6	4,5	3,3	3,4	2,4
	outriggers up			8,8*	4,8	5,3	3,1	3,7	2,2	2,8	1,6
+ 1,5 m	outriggers down			9*	7	6,3	4,4	4,4	3,1	3,3	2,4
	outriggers up			8,2	4,4	5	2,9	3,6	2,1	2,7	1,6
0 m	outriggers down			6,1*	6,1*	5,6*	4,3	4,2*	3,1	3,1*	2,4
	outriggers up			6,1*	4,1	4,9	2,7	3,5	2	2,7	1,5
- 1,0 m	outriggers down					4,7*	4,2*	3,6*	3		
	outriggers up					4,7*	2,7	3,4	2		

The specified max. loading capacities in tonnes include a stability of 33% or are calculated at 87% of the hydraulic lifting power, as per ISO10567. These values are applicable at the tip of the arm with optimum positioning of the corresponding arm system. * Value limited due to hydraulics. Weights of attached load carrying accessories (grab, magnet, load hook, etc.) are not included with the load carrying values.

Lifting capacities

Adjustable Boom, Base Arm 1,87 m (C6.41) and Boom 3,10 m (C6.46)

+ Stick 2,65 m (D6.3), Max. reach 9,20 m

Lifting capacities 180MH: Base Arm 1,87 m (C6.41) and Boom 3,10 m (C6.46) + Stick 2,65 m (D6.3), Max. Reach 9,20 m

HEIGHT		3,0 m		4,5 m		6,0 m		7,5 m	
		FRONT	LATERAL	FRONT	LATERAL	FRONT	LATERAL	FRONT	LATERAL
+ 6,0 m	DB raised in the back			4,1*	4,0	3,7*	2,5		
	DB lowered in the back			4,1*	4,1*	3,7*	2,8		
	Outriggers lowered			4,1*	4,1*	3,7*	3,7*		
	DB / Outriggers lowered			4,1*	4,1*	3,7*	3,7*		
+ 4,5 m	DB raised in the back			4,5*	3,9	3,8*	2,6		
	DB lowered in the back			4,5*	4,3	3,8*	2,9		
	Outriggers lowered			4,5*	5,1*	3,8*	3,8*		
	DB / Outriggers lowered			4,5*	5,1*	3,8*	3,8*		
+ 3,0 m	DB raised in the back	7,1*	6,7*	5,2*	3,8	4,1*	2,6	2,9	1,7
	DB lowered in the back	7,1*	7,1*	5,2*	4,1	4,1*	2,8	3,4*	1,9
	Outriggers lowered	7,1*	7,1*	5,2*	5,2*	4,1*	4,1*	3,4*	3,1
	DB / Outriggers lowered	7,1*	7,1*	5,2*	5,2*	4,1*	3,8	3,4*	2,7
+ 1,5 m	DB raised in the back	8,4*	6,4	5,9*	3,7	4,0	2,5	2,9	1,6
	DB lowered in the back	8,4*	7,1	5,9*	4,0*	4,3*	2,8	3,4*	1,8
	Outriggers lowered	8,4*	8,4*	5,9*	5,9*	4,3*	4,2*	3,4*	3,1
	DB / Outriggers lowered	8,4*	8,4*	5,9*	5,5	4,3*	3,8	3,4*	2,7
+ 0 m	DB raised in the back	9,4*	6,4	5,9*	3,6	4,0	2,4	2,8	1,6
	DB lowered in the back	9,4*	7,1	6,0*	4,0	4,3*	2,6	3,2*	1,8
	Outriggers lowered	9,4*	9,4*	6,0*	6,0*	4,3*	4,2	3,2*	3,0
	DB / Outriggers lowered	9,4*	9,4*	6,0*	5,5	4,3*	3,8	3,2*	2,6
- 1,5 m	DB raised in the back	9,9*	6,0	6,0	3,4	3,9	2,2		
	DB lowered in the back	9,9*	6,8	6,1*	3,8	4,4*	2,4		
	Outriggers lowered	9,9*	10,0*	6,1*	6,1*	4,4*	4,2		
	DB / Outriggers lowered	9,9*	10,0*	6,1*	5,6	4,4*	3,6		
- 3,0 m	DB raised in the back	10,3*	6,0	6,0*	3,3				
	DB lowered in the back	10,3*	6,8	6,0*	3,6				
	Outriggers lowered	10,3*	10,3*	6,0*	6,0*				
	DB / Outriggers lowered	10,3*	10,3*	6,0*	5,5				

Lifting capacities 200MH: Base Arm 1,87 m (C6.41) and Boom 3,10 m (C6.46) + Stick 2,65 m (D6.3), Max. Reach 9,20 m

HEIGHT		3,0 m		4,5 m		6,0 m		7,5 m	
		FRONT	LATERAL	FRONT	LATERAL	FRONT	LATERAL	FRONT	LATERAL
+ 6,0 m	DB raised in the back			4,1*	4,1*	3,7*	2,9		
	DB lowered in the back			4,1*	4,1*	3,7*	3,3		
	Outriggers lowered			4,1*	4,1*	3,7*	3,7*		
	DB / Outriggers lowered			4,1*	4,1*	3,7*	3,7*		
+ 4,5 m	DB raised in the back			4,5*	4,4	3,8*	3,0		
	DB lowered in the back			4,5*	4,5*	3,8*	3,3		
	Outriggers lowered			4,5*	4,5*	3,8*	3,8*		
	DB / Outriggers lowered			4,5*	4,5*	3,8*	3,8*		
+ 3,0 m	DB raised in the back	7,1*	7,1*	5,3*	4,3	4,1*	2,9	3,3	2,0
	DB lowered in the back	7,1*	7,1*	5,3*	4,7	4,1*	3,2	3,4*	2,2
	Outriggers lowered	7,1*	7,1*	5,3*	3,5*	4,1*	4,1*	3,4*	3,4*
	DB / Outriggers lowered	7,1*	7,1*	5,3*	3,5*	4,1*	4,1*	3,4*	3,1
+ 1,5 m	DB raised in the back	8,4*	7,2	6,0*	4,2	4,3*	2,9	3,3	1,9
	DB lowered in the back	8,4*	8,0	6,0*	4,6*	4,3*	3,2	3,4*	2,2
	Outriggers lowered	8,4*	8,4*	6,0*	5,9*	4,3*	4,3*	3,4*	3,4*
	DB / Outriggers lowered	8,4*	8,4*	6,0*	5,9*	4,3*	4,2	3,4*	3,0
+ 0 m	DB raised in the back	9,5*	7,2	6,0*	4,2	4,4*	2,8	3,2*	1,9
	DB lowered in the back	9,5*	8,1	6,0*	4,6	4,4*	3,1	3,2*	2,1
	Outriggers lowered	9,5*	9,5*	6,0*	6,0*	4,4*	4,4*	3,2*	3,2*
	DB / Outriggers lowered	9,5*	9,5*	6,0*	6,0*	4,4*	4,2	3,2*	3,0
- 1,5 m	DB raised in the back	9,9*	6,9	6,1*	4,0	4,5*	2,6		
	DB lowered in the back	9,9*	8,0	6,1*	4,5	4,5*	2,9		
	Outriggers lowered	9,9*	9,9*	6,1*	6,1*	4,5*	4,5*		
	DB / Outriggers lowered	9,9*	9,9*	6,1*	6,1*	4,5*	4,1		
- 3,0 m	DB raised in the back	10,3*	6,9	6,0*	3,8				
	DB lowered in the back	10,3*	8,0	6,0*	4,3				
	Outriggers lowered	10,3*	10,3*	6,0*	6,0*				
	DB / Outriggers lowered	10,3*	10,3*	6,0*	6,0*				

The specified max. loading capacities in tonnes include a stability of 33% or are calculated at 87% of the hydraulic lifting power, as per ISO10567. These values are applicable at the tip of the arm with optimum positioning of the corresponding arm system. * Value limited due to hydraulics. Weights of attached load carrying accessories (grab, magnet, load hook, etc.) are not included with the load carrying values. DB= Dozer blade

180MH/200MH

Working ranges

Adjustable Boom, Base Arm 1,87 m (C6.41) and Boom 3,10 m (C6.46)
+ Stick 2,65m (D6.3)

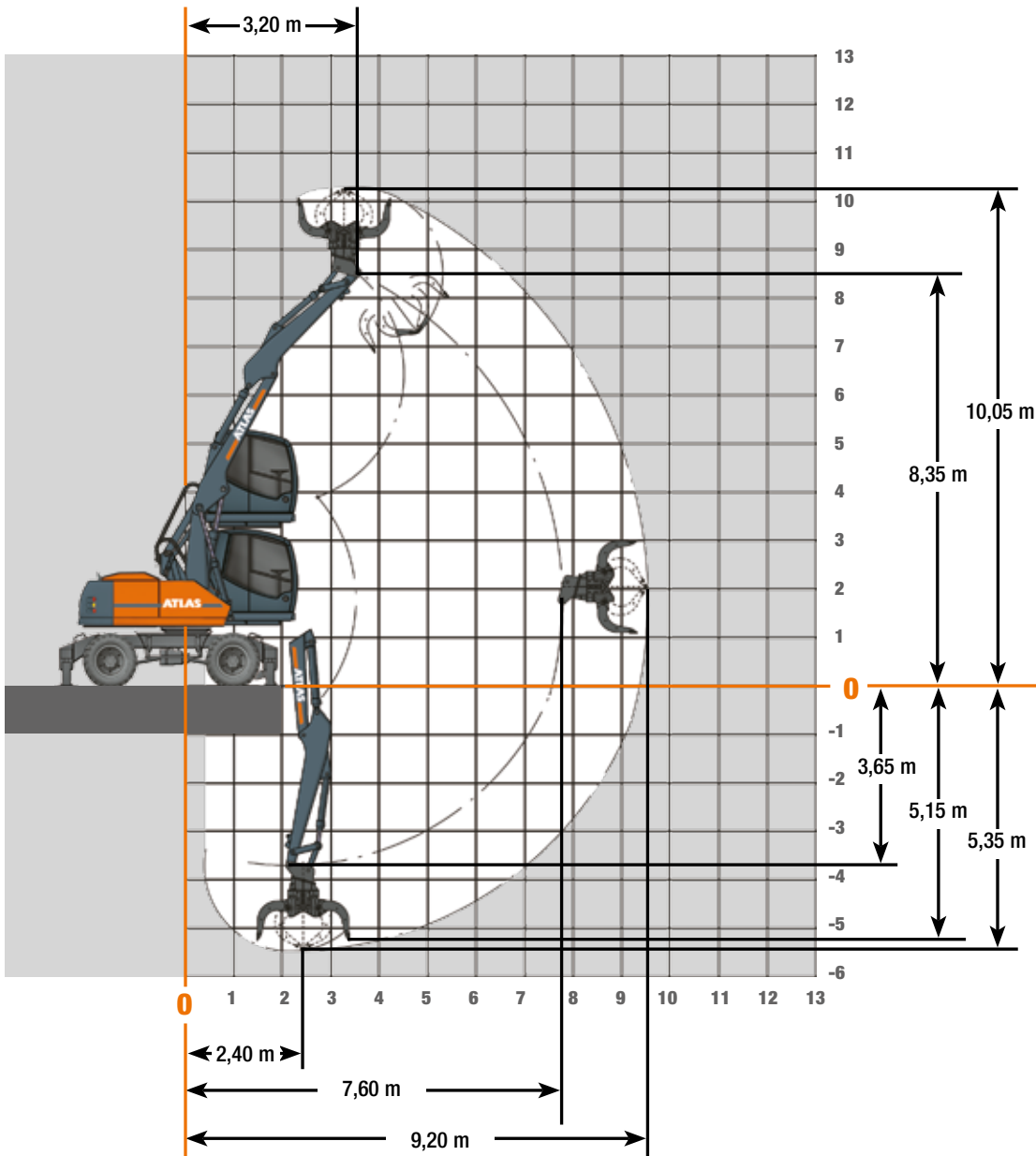

Attachments

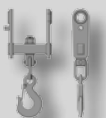

Load hook

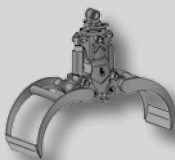

Log grab

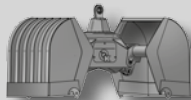

Clamshell grab

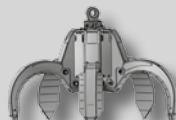

Orange peel grab



Load lifting magnet

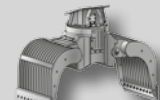

Sorting grapple

WORKING RANGES

Dimensions

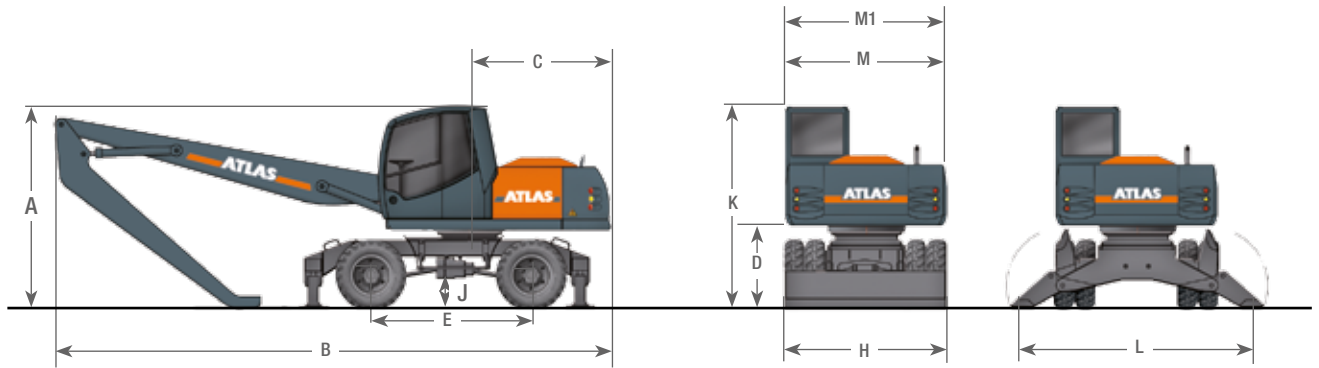

A	TRANSPORT HEIGHT	D	CLEARANCE HEIGHT TO COUNTERWEIGHT	1,22 m
	Adjustable boom* Stick 2,65 m	E	WHEEL BASE	2,50 m
	Loading boom 6,0 m with Stick 4,0 m	H	DOZER BLADE WIDTH	2,49 m
	Loading boom 6,0 m with Stick and tipping cylinder 4,0 m	J	GROUND CLEARANCE	0,45 m
B	TRANSPORT LENGTH	K	HEIGHT ABOVE CAB	3,08 m
	Adjustable boom* Stick 2,65 m	L	OUTRIGGER WIDTH (extended)	3,50 m
	Loading boom 6,0 m with Stick 4,0 m	M	SUPERSTRUCTURE TRANSPORT WIDTH	2,49 m
	Loading boom 6,0 m with Stick and tipping cylinder 4,0 m	M1	SUPERSTRUCTURE TRANSPORT WIDTH WITH LIFT	2,65 m
8,40 m			
C	REAR PIVOTING RADIUS			
2,19 m			

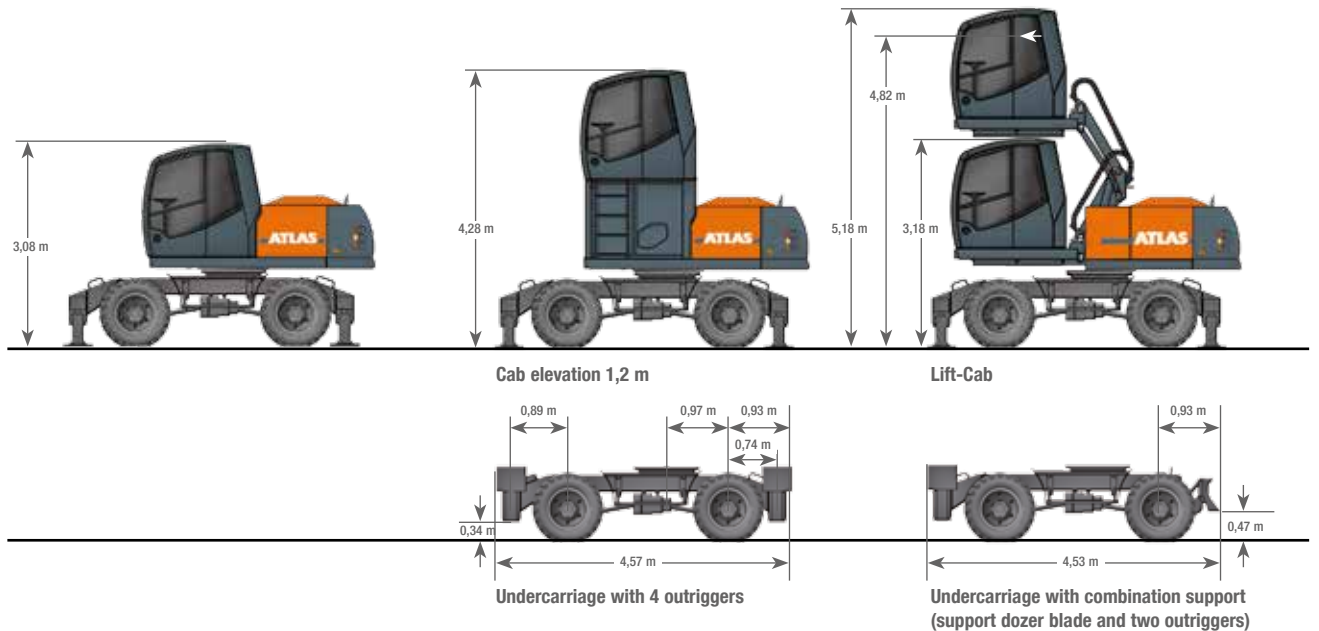

www.atlasgmbh.com

ATLAS Maschinen GmbH
EXCAVATORS
Atlasstrasse 6
27777 Ganderkesee, Germany
T: +49 (0) 4222 954 0
F: +49 (0) 4222 954 343
info@atlasgmbh.com

180MH/200MH-EN (1) Effective date: August 2010. Product specifications and prices are subject to change without notice or obligation. The photographs and/or drawings in this document are for illustrative purposes only. Refer to the appropriate Operator's Manual for instructions on the proper use of this equipment. Failure to follow the appropriate Operator's Manual when using our equipment or to otherwise act irresponsibly may result in serious injury or death. The only warranty applicable to our equipment is the standard written warranty applicable to the particular product and sale and Atlas makes no other warranty, express or implied. The only warranty applicable to our equipment is the standard written warranty applicable to the particular product and sale and Atlas makes no other warranty, express or implied. Products and services listed may be trademarks, service marks or trade-names of Atlas Maschinen GmbH and/or its subsidiaries. All rights are reserved. Atlas® is a registered trademark of Atlas Maschinen GmbH. Copyright © 2010 Atlas Maschinen GmbH.